

Imperial [IP] Dimensions
Metric (SI) In Parentheses

CARNES COMPANY, 448 S. Main St., P. O. Box 930040, Verona, WI. 53593-0040 Phone: 608/845-6411 Fax: 608/845-6470 E-Mail: carnes@carnes.com www.carnes.com

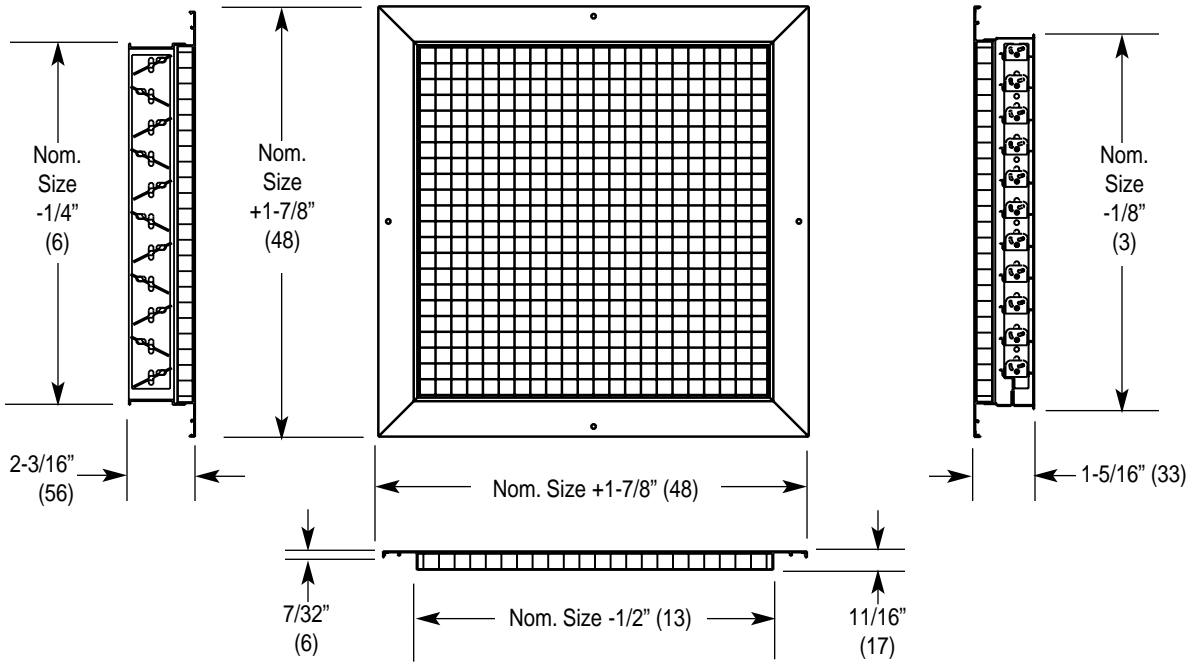

Standard Screw Mounting ("Y")

Screw is #6 x 1-1/4"
Countersunk head.

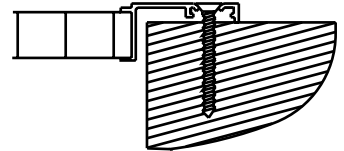

Option "N" (No Screw Holes)

When ordered with this option, the following sizes will fit the following suspended ceiling grids with no modification required.

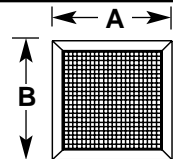

Notes:

1. Standard finish is electrocoat acrylic baked enamel.
2. Standard color is #11 Bright White.
3. Core and frame are aluminum.
4. Damper is operated via flat-blade screwdriver inserted into one corner.
5. Maximum single panel size is 48" x 36". Panels can be joined together for larger sizes.
6. Damper on Model RNPAF is aluminum model RXFA.
7. Damper on Model RWPAF is electrogalvanized steel model RXEA.
8. Metric dimensions are given in millimeters.

| Nominal Size | Has This O. D. [A x B] | and Fits This T-bar |
|--------------|--------------------------------|---------------------|
| 10" x 10" | 11-7/8" x 11-7/8" (302 x 302) | 12" x 12" |
| 10" x 22" | 11-7/8" x 23-7/8" (302 x 606) | 12" x 24" |
| 22" x 22" | 23-7/8" x 23-7/8" (606 x 606) | 24" x 24" |
| 22" x 46" | 23-7/8" x 47-7/8" (606 x 1216) | 24" x 48" |