

Imperial [IP] Dimensions
Metric (SI) In Parentheses

CARNES COMPANY, 448 S. Main St., P.O. Box 930040, Verona, WI. 53593-0040 Phone: 608/845-6411 Fax: 608/845-6470 E-Mail: carnes@carnes.com www.carnes.com

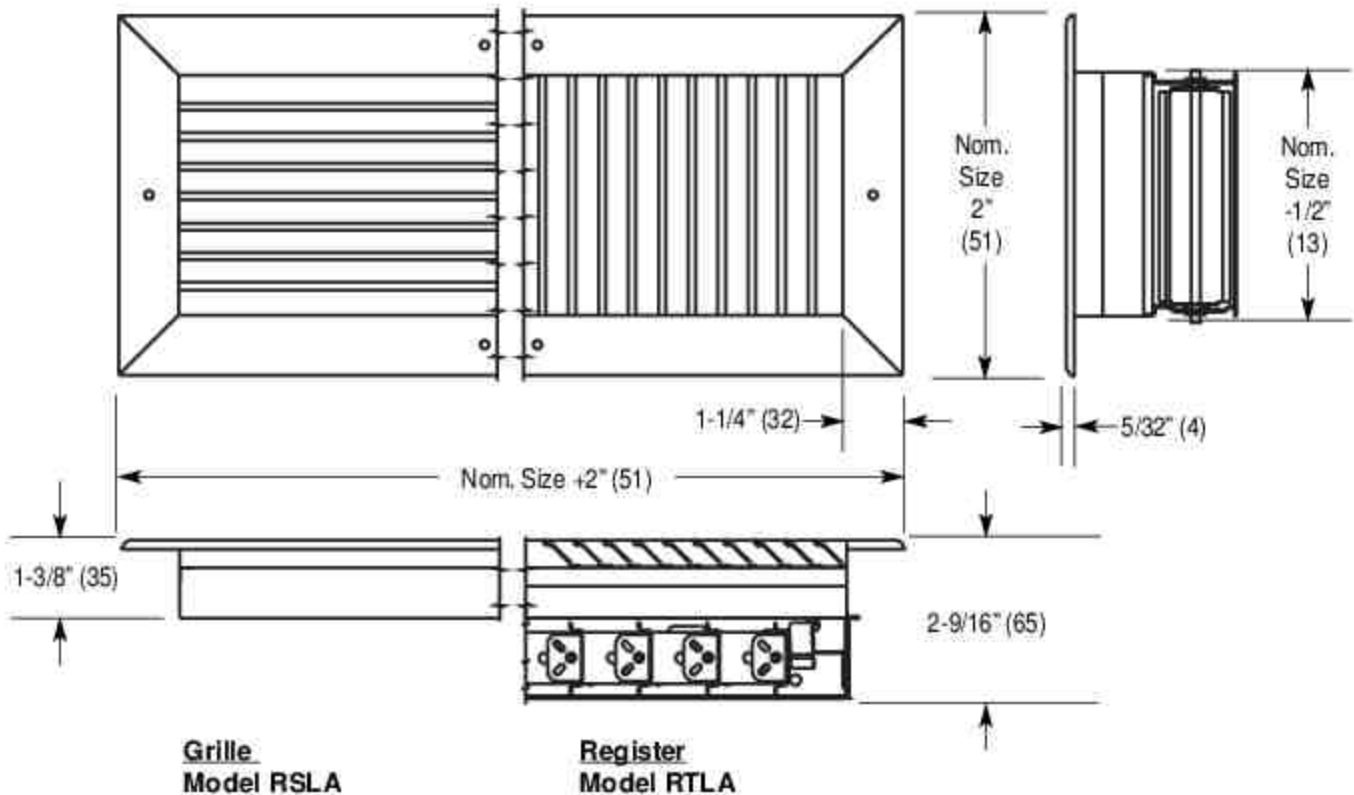

Notes

1. Standard screws are #6 x 1-1/4" (32) phillips trusshead screws.
2. The standard finish is electrocoat acrylic baked enamel. Other finishes are available on request.
3. The standard color is #11 Bright White. Other colors are available on request.
4. Louvers can be aligned either horizontally or vertically.
5. Louver edges are hemmed for extra strength and safety.
6. Standard sizing is in even inch increments in both dimensions.
7. Odd inch and fractional sizing (in 1/8" increments) is available on request.
8. Damper construction is electrogalvanized steel.
9. The standard operator on the damper takes a medium size flat-blade screwdriver.
10. Maximum size shown is the maximum single panel size. Panels can be joined for larger sizes.
11. Metric dimensions are given in millimeters.

Model	Damper	Blade Alignment	Minimum W x H	Maximum W x H
RSLAH	No	Horizontal	4' x 4' (102 x 102)	48' x 36' (1219 x 914)
RSLAV	No	Vertical		36' x 48' (914 x 1219)
RTLAH	Yes	Horizontal		48' x 36' (1219 x 914)
RTLAV	Yes	Vertical		36' x 48' (914 x 1219)