

D U C T M A T E

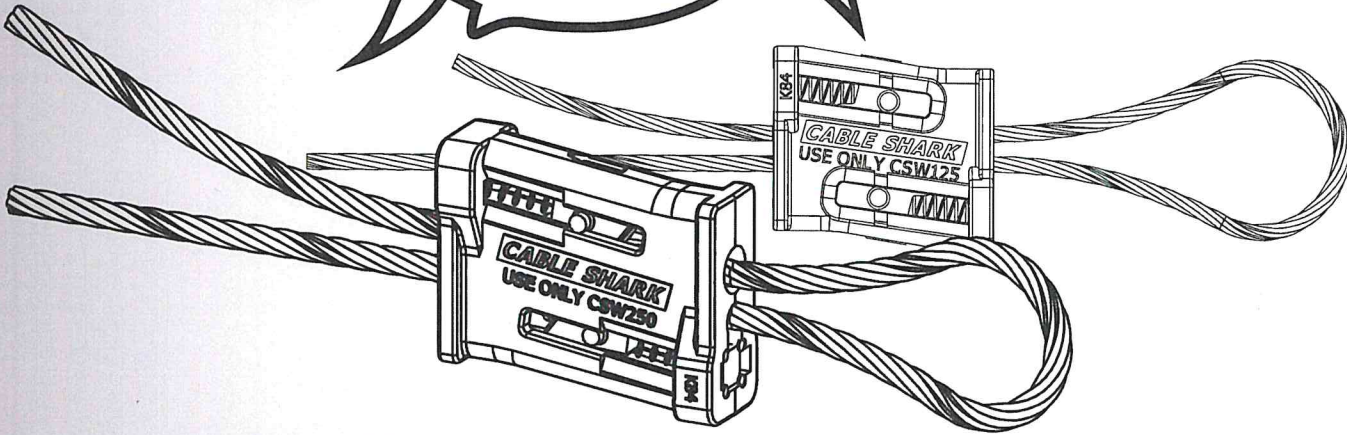
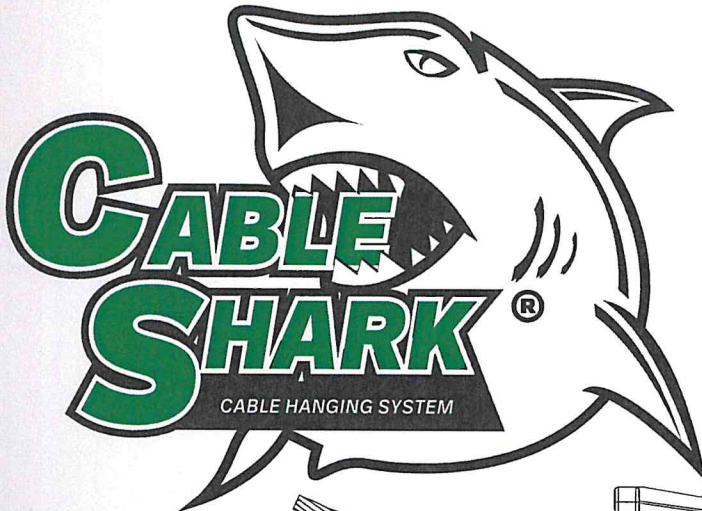

Cable Hanging System

Labor-saving, versatile means for hanging static load HVAC Systems

- Meets SMACNA upper and lower attachment construction standards if used per manufacturer's installation guidelines
- Comprehensive Cable Shark Hanging System Load Charts and Installation Videos available online at Ductmate.com
- Meets ICC-ES AC284 guidelines
- Engineered for strength and durability
- Fast and easy installation
- Available in cut-to-length sizes with ferruled loop or spools
- Compact design is aesthetically pleasing
- Available in 2 sizes to meet specific load ranges
- Versatile hanging options for nearly every application

IMPORTANT INFORMATION

Before use or installation of product, read and follow all product information and warnings. Do not use product in a manner that is inconsistent with the manufacturer's printed information. Ensure all employees installing the Cable Shark System have been properly trained on the use of this product.



DUCTMATE[®]
Industries, Inc.

SAFETY

The Cable Shark system has been engineered and tested to meet SMACNA upper and lower attachment safety standards. The vertical load limit of the system is the maximum amount that can be supported. When designing a HVAC system for use with the Cable Shark system, do not exceed the load limit of the Cable Shark system.

DESCRIPTION

The Ductmate Cable Shark Cable Hanging System consists of Ductmate Cable Shark Cable and the Ductmate Cable Shark mechanism. For the system to work properly, both components must be used. Ductmate Cable Shark Cable is the only cable tested and approved for use with the Ductmate Cable Shark system. Use of any other cable is prohibited and will void the Ductmate warranty.

The Cable Shark mechanism uses two serrated steel wedges to grip the Cable Shark Cable (Fig. 1a). The housing of the mechanism is zinc die cast. The shape and orientation of the wedge allows the Cable Shark Cable to pass through in one direction (arrows cast on mechanism indicate direction). When a load is applied to the Cable Shark Cable, the wedge grips the Cable Shark Cable and presses it against the Cable Shark mechanism housing, preventing it from moving (Fig. 1b).

The Cable Shark mechanism has two bores or passages. Each bore contains the wedge mechanism described above.

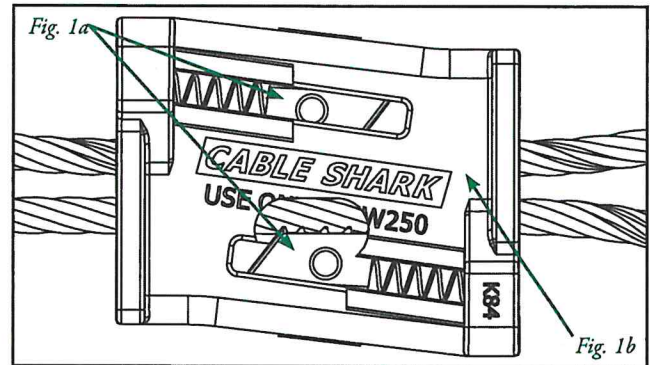

BASIC USE

The Ductmate Cable Shark System is a labor-saving, steel cable hanging system for the suspension of static load HVAC Systems.

SPECIAL CHARACTERISTICS

- Meets SMACNA upper and lower attachment construction standards if used per manufacturer's installation guidelines
- Comprehensive Cable Shark Hanging System Load Charts and Installation Videos available at Ductmate.com
- Meets ICC-ES AC284 guidelines
- Engineered for strength and durability
- Fast and easy installation
- Available in cut-to-length sizes with ferruled loop or spools
- Compact design is aesthetically pleasing
- Available in 2 sizes to meet specific load ranges
- Versatile hanging options for nearly every application

TECHNICAL INFORMATION

Cable Shark Mechanism

HOUSING: Zinc Cast

WEDGE: Hardened Steel

SPRING: Steel

END CAP: Zinc Cast

Cable Shark Cable

The Ductmate Cable Shark System has been designed and rigorously tested to be exclusively compatible with Ductmate Cable Shark Cable.

PACKAGING INFORMATION

Size	Box Quantity	Bag Quantity	Bags/Boxes
CS125	180	6	30
CS250	120	4	30

STABILITY IN THE DUCT SYSTEM

When installed, the duct system should be stable enough that it does not swing or move when in use. Excessive movement can lead to fatigue failures in the joints or connections.

Typically, a duct run will be attached to some rigid object, such as a wall or equipment at one or both ends of the run.

When a run of duct is anchored only at one end and cantilevered outward, the free end of the run can be expected to swing laterally (Fig. 7a). When a long run of duct is anchored at both ends, the free center of the duct run may swing laterally (Fig. 7b). If two sections of duct anchored at one end converge at a 90° angle (Fig. 7c), free sections of duct may swing laterally.

In an application where movement is not expected, the single point saddle method (Fig. 2), the standard horseshoe method (Fig. 3), and the standard loop (Fig. 5) can be used. When lateral movement needs to be minimized, the spread horseshoe (Fig. 4) should be used.

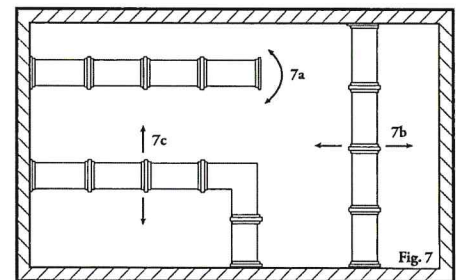

CAUTION



Never exceed the **WORKING LOAD LIMIT**. In calculating working load, the full weight of the duct with contents, controls, and accessories must be calculated.



Loads should be carried evenly across all hanging points.



Use only with static loads. Not intended for use with oscillating loads.



Prior to use, store product in a clean, dry and safe condition.



Always check that the wedges are fully engaged.



Do not apply paint, lubricants or other coatings to the Cable Shark system.

Advise all applicable parties and post notices as necessary to ensure that paint, lubricants, and/or other coatings are not applied during the installation or in the future.

SYSTEM DIRECTIONS

Attaching the Cable Shark mechanism to the Cable Shark Cable is quick and easy. Insert the Cable Shark Cable through the first bore of the Cable Shark mechanism following the directional arrow marked on the outside of the housing. Loop the Cable Shark Cable through the upper attachment then back through the opposing bore of the Cable Shark mechanism following the directional arrow marked on the outside of the housing. At least 3" (7.62 cm) of Cable Shark Cable must extend out of the Cable Shark mechanism. Repeat the process with a second Cable Shark if needed.

Tip: When cutting Cable Shark Cable, use a quality cutter designed for cable. Tin snips, diagonal cutters, and electrical cable cutters will not work; they will fray the ends of the Cable Shark Cable and prevent it from sliding into the Cable Shark mechanism correctly.

Method 1

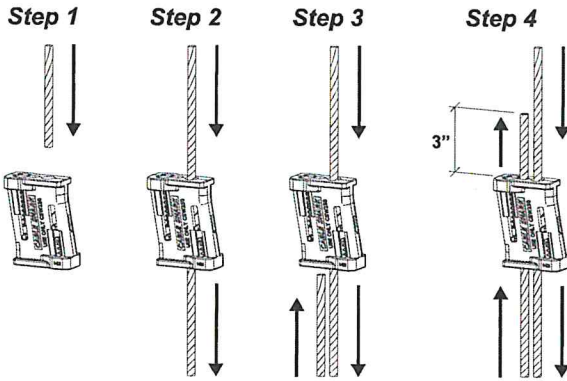

Method 2

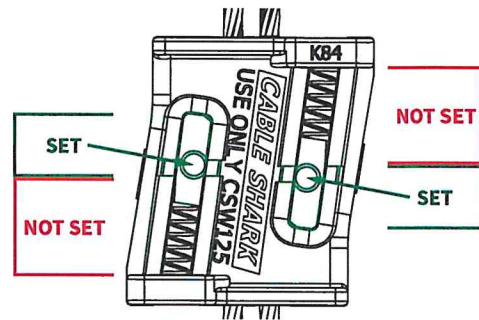
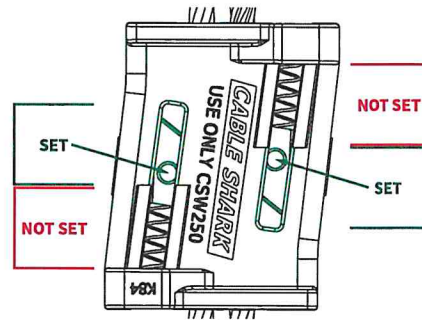
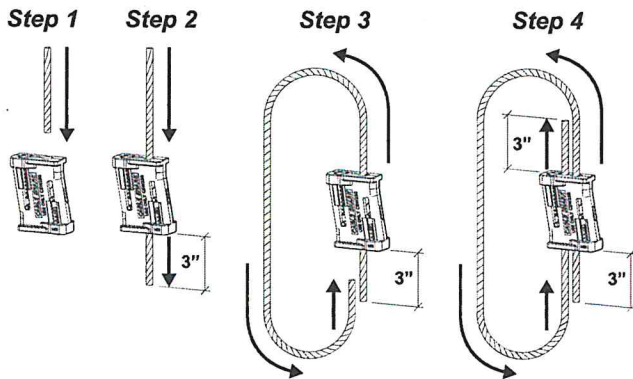

Always Make Sure the Cable is Engaged by Aligning the Pin to the Marks or by Fully Seating the Wedge in the Housing

MAXIMUM LOADS - NON VERTICAL

Single Point and Spread Horse Shoe Suspension Limits
Note these limitations are valid when two Cable Shark mechanisms or one Cable Shark and a ferrule loop are utilized.

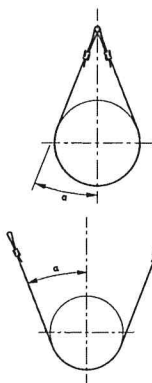

Angle	CS125 Max Load (lbs)	CS250 Max Load (lbs)
0°	250	500
5°	250	500
10°	250	500
15°	250	500
20°	250	500
25°	250	500
30°	250	480
35°	241	454
40°	226	425
45°	208	392
50°	189	356
55°	169	318
60°	147	277

VERTICAL LOAD LIMITS

Reference Cable Shark Duct Construction Standards for comprehensive load charts.

Cable Shark System	Maximum Load	Required Cable Shark Cable
CS125	125 lbs. (56.69 kg)	CSW125
CS250	250 lbs. (113.39 kg)	CSW250

WARNING

DO NOT attempt to use the Cable Shark mechanism to splice two cables together, or attempt to secure the Cable Shark Cable via only one bore in the Cable Shark mechanism. The same Cable Shark Cable must pass through both bores in the Cable Shark mechanism.

A 3" (7.62 cm) minimum length of cable must be left protruding from the locking mechanism.



Do not use the Cable Shark hanging system for lifting.



Do not use in corrosive or extremely humid conditions. Such conditions, over time, can cause metal components to corrode and fail.



Do not stand or walk on duct system.



When adjusting or disconnecting Cable Shark system, always make sure that load is fully supported by other means.



Be sure the building structure is capable of supporting the weight of the load.



Use an appropriate hanging method to prevent lateral movement in suspended duct.

HANGING CONFIGURATIONS

The type of hanging configuration used depends on the application. For rectangular and oval ductwork, only use Standard or Spread Horseshoe configuration. It is up to the end user to determine the best configuration for their particular installation. Consult the Construction Standards for more information about selecting the best hanging configuration for the application.

The first method is called the single point saddle method (Fig. 2). This method is to be the primary hanging method when using the Cable Shark mechanism. The Cable Shark Cable is looped through a suitable suspension point that is attached to the top support and then secured with one or two Cable Sharks as shown below. Maximum load limits for this configuration are shown in the table below. The Single Point Saddle cannot be used with oval rectangular ducts.

The second method is the standard horseshoe (Fig. 3). In this method, the Cable Shark Cable is looped around the upper support and secured with a Cable Shark mechanism, then routed under the ductwork and back up to a second support to be secured with another Cable Shark mechanism (alternate standard horseshoe configurations also shown). This method helps to eliminate some swinging in the ductwork. Using two Cable Shark mechanisms on a single cable at separate attachment points does not change the maximum stated load rating. The maximum load capacity of the Cable Shark 125 and 250 in this configuration is 250 lbs and 500 lbs respectively.

Next is the spread horseshoe method (Fig. 4). This configuration has the same cable routing as the standard horseshoe, but the distance between the suspension points is greater than the width of duct being hung creating a measure of cross bracing. This configuration can be used when additional stability is desired. Items can be hung at angles up to 60° from vertical. Maximum load limits for this configuration are shown in the table below.

The last method is the standard loop (Fig. 5). The Cable Shark Cable is looped around the upper support and secured with a Cable Shark mechanism, then looped around the duct and secured with another Cable Shark mechanism. The advantage of this method is its simplicity. It is suitable for applications where the duct will not experience lateral forces or be prone to swinging. An example of this would be a duct that is attached to a wall or other fixed element on each end. This configuration can be used for general purpose hanging, however this method cannot be used with oval or rectangular ducts. **The Cable Shark 250 used in the standard loop is only permitted for use on round duct diameters 18" (45.72 cm) or less without limitation. The Cable Shark 125 is limited to round duct diameters 10" (25.4 cm) or less without limitation. When used with round duct over these diameters, the device must be placed at a distance of 1/2 the diameter of the duct above the duct (Fig 6). The maximum load capacity of the Cable Shark 125 and 250 in this configuration is 125 lbs and 250 lbs respectively. Contact Ductmate for applications beyond these published limitations.**

Fig. 2 - Single Point Saddle Approved Configurations

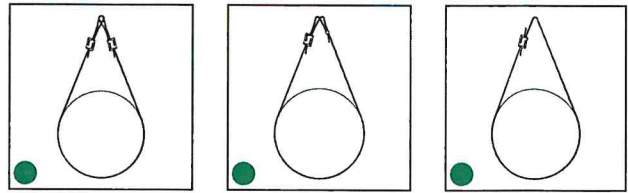

Fig. 3 - Standard Horseshoe Approved Configurations

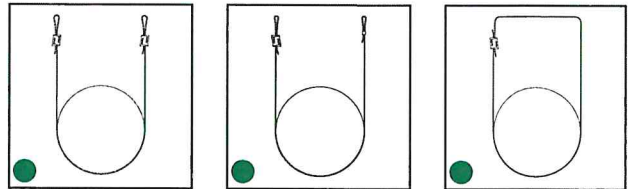

Fig. 4 - Spread Horseshoe Approved Configurations

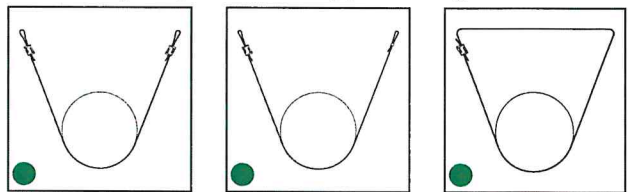
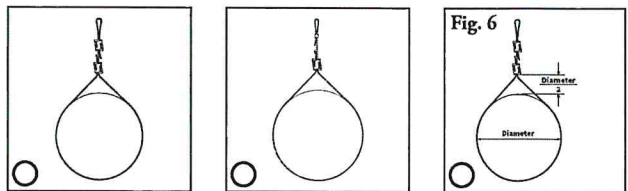

Fig. 5 - Standard Loop Approved Configurations



● CS125 - MAX 250 lbs
CS250 - MAX 500 lbs ○ CS125 - MAX 125 lbs
CS250 - MAX 250 lbs

ASSEMBLY EXAMPLES

ROUND DUCT

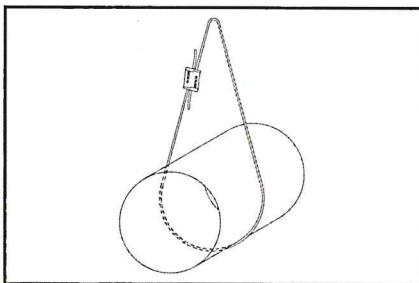

OVAL DUCT

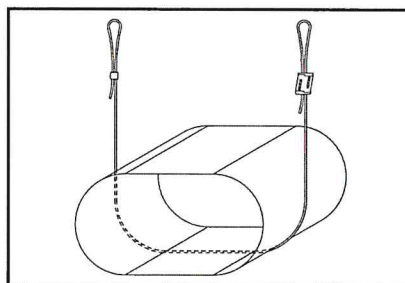

RECTANGULAR DUCT

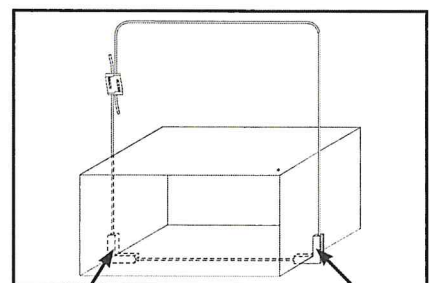

Rectangular Duct Corner Saddles
Part No. HFCCS

The Corner Saddle is designed to eliminate abrasion of rectangular ductwork with the use of a Cable Shark Cable hanging system.



For extreme temperature ranges consult design engineer.



Do not reuse Cable Shark system.



Do not attempt to use the Cable Shark mechanism to splice two cables together, or attempt to secure the Cable Shark Cable via only one bore in the Cable Shark mechanism.



Do not use the Standard Loop or Single Point Saddle Configuration with rectangular or oval duct.



Care should be taken that sharp edges do not come in contact with the system and abrade or damage the Cable Shark Cable.



When used as a supplementary support, duct being suspended cannot exceed maximum load rating of the Cable Shark system.

INSTALLATION INSTRUCTIONS - Upper Attachment

Upper Attachment - ALL Hanging Methods

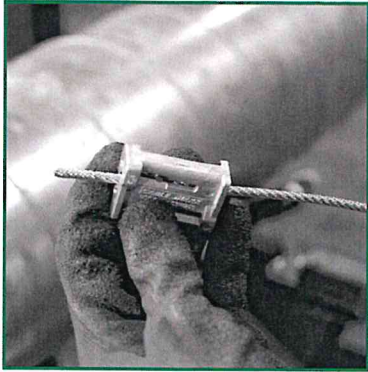

1. Insert Cable Shark Cable through one side of Cable Shark mechanism following the directional arrow.

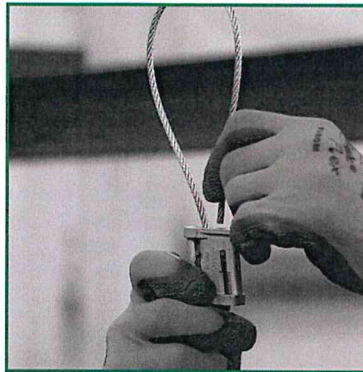

2. Loop cable through fixed upper attachment and through the second side of the Cable Shark following the directional arrow, pull tightly on the cable.

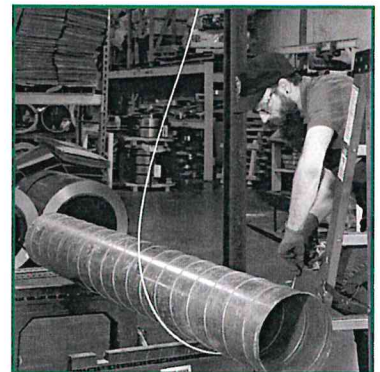

3. Loop the Cable Shark Cable around duct being suspended.

INSTALLATION INSTRUCTIONS - Second Attachment

Single Point Saddle



4. Insert Cable Shark Cable through one side of a second Cable Shark following the directional arrow. Then loop through the same fixed upper attachment and back through the Cable Shark following the directional arrow, pull tightly on the cable.

Standard / Spread Horseshoe

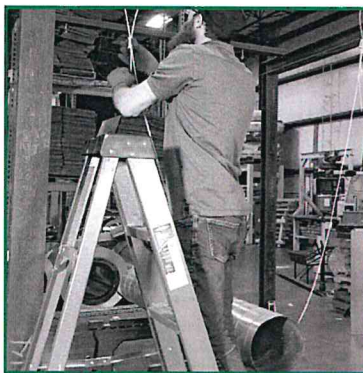

4. Insert Cable Shark Cable through one side of a second Cable Shark following the directional arrow. Then loop through the second fixed upper attachment and back through the Cable Shark following the directional arrow, pull tightly on the cable.

Standard Loop

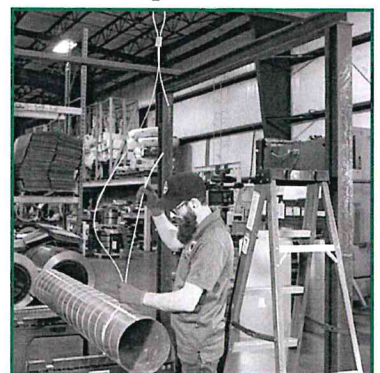

4. Insert Cable Shark Cable through one side of a second Cable Shark following the directional arrow. Loop cable around duct then back through the Cable Shark following the directional arrow, pull tightly on the cable.

INSTALLATION INSTRUCTIONS - Finish Installation

Finish Installation - ALL Hanging Methods



5. Level duct by adjusting the length of Cable Shark Cable at each suspension point.



6. Tension the Cable Shark Cable with a tensioning tool using the tension rating as noted in the device size name. Also ensure the steel wedges are past the indicator on the device.

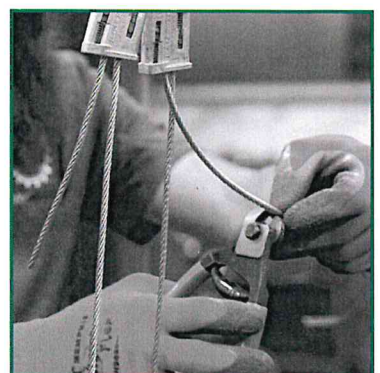

7. Trim all excess from Cable Shark Cable to no less than 3".

WARNING - Before Installation Is Completed

Make sure the load is evenly distributed over ALL Cable Shark mechanisms and that ALL Cable Shark mechanisms are engaged.

CABLE SHARK CABLE

Zinc coated Cable Shark Cable available in 7 x 7 strand construction.

BASIC USE

Ductmate Cable Shark Cable is designed for the suspension of HVAC systems. The Ductmate Cable Shark System and Ductmate Cable Shark Cable must always be used in conjunction. **Use of any other steel cable is prohibited.**

SPECIAL CHARACTERISTICS

- Engineered for superior strength
- Supplied in spools of 500' and 1,000' or cut to length
- Cable Shark 125 Cable is only compatible with the Cable Shark 125
- Cable Shark 250 Cable is only compatible with the Cable Shark 250
- Available in cut-to-length sizes with ferruled loop on one end

PACKAGING INFORMATION

Cable Shark Cable: Spools

Part Number	Length	For Use With
CSW125500	500' Spool	CS125
CSW1251000	1,000' Spool	CS125
CSW250500	500' Spool	CS250
CSW2501000	1,000' Spool	CS250

Cable Shark Cable: Cut-to-Length with Ferruled Loop on One End

Part Number	Length	Bag Quantities	
		CSW125	CSW250
CSW*005	5'	12	8
CSW*010	10'	12	8
CSW*015	15'	12	8
CSW*020	20'	12	8

* Insert 125 for CSW125 Cable
Insert 250 for CSW250 Cable

ACCESSORIES



Ductmate Light Duty Cable Shark Cable Cutter

A small, high-quality cutter compatible with Cable Shark Cable. Tin snips, diagonal cutters, and electrical Cable cutters fray the ends of the Cable Shark Cable and prevent it from sliding into the Cable Shark mechanism correctly. The Ductmate Cable Shark Cable Cutter provides a clean cut with less effort.

(Part Number: HFWRC)

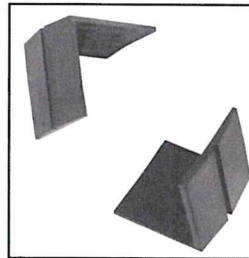

Rectangular Duct Corner Saddles

The Corner Saddle is designed to eliminate abrasion of rectangular ductwork with the use of a Cable Shark Cable hanging system. Corner Saddles can be used when hanging rectangular duct with Ductmate's Cable Shark/Cable Rope System.

Part Number: HFCCS

No minimum order quantity required



Tension Tool

The Cable Shark System is designed to work with this cable hanging system Tension Tool. When used per the manufactures instructions, this tool applies a uniform pre-load to each Cable Shark device and ensures proper function of the Cable Shark System.

Part Number: HFTTM

LIMITED PRODUCT WARRANTY

Ductmate warrants that Cable Shark, when properly installed and maintained, will be free from defects in material and workmanship, and will comply with all written specifications made by Ductmate at the time of sale. Ductmate's warranty shall run for a period of one year from the date of manufacture.

Warranty Limitation

The warranty stated above is in lieu of all other warranties, express or implied, including but not limited to the implied warranties of MERCHANTABILITY AND FITNESS FOR A PARTICULAR PURPOSE. Although Ductmate may have suggested the product, or provided written or oral advice to the Purchaser, it is the Purchaser's responsibility to test and determine the suitability of Cable Shark, for the intended use and purpose, and Purchaser and/or its customer assumes all risk and liability whatsoever regarding such suitability.

Limitation of Liability

In the event of a breach of the above warranty, Ductmate's sole obligation, and Purchaser's sole and exclusive remedy, shall be, at Ductmate's option, repair or replacement of any defective products, or refund of an applicable portion of the purchase price. Ductmate shall have no liability for costs of removal or reinstallation of the product. The Purchaser agrees that no other remedy, including but not limited to loss of profits, loss sales, injury to person or property, or any other special, incidental or consequential damages, shall be available to the Purchaser for any claim arising out of this Agreement, regardless of whether such claim is made in contract or in tort, including strict liability in tort. In no event will Ductmate be obligated to pay damages to the Purchaser in any amount exceeding the purchase price that the Purchaser paid to Ductmate for the allegedly defective product.

WARNING

When adjusting a Cable Shark mechanism, be sure that the load is supported by alternate means before pulling back on the wedge and releasing the Cable Shark Cable.



Charleroi, PA
210 Fifth Street
Charleroi, PA 15022
724-258-0500

Lodi, CA
810 S. Cluff Avenue
Lodi, CA 95240-9141
209-333-4680

Additional Manufacturing and Warehousing in Monongahela, PA and Wagoner, OK

1-800-245-3188 • www.ductmate.com

© Copyright Ductmate Industries, Inc. All rights reserved.



Ductmate is A Proud Member Of The Following Organizations:



Distributed By: