

Imperial [IP] Dimensions
Metric (SI) on Reverse Side

MODEL VEDK - DIRECT DRIVE
ROOF VENTILATOR

CARNES COMPANY, Verona, WI. Phone: 608-845-6411 Fax: 608-845-6470 carnes@carnes.com www.carnes.com

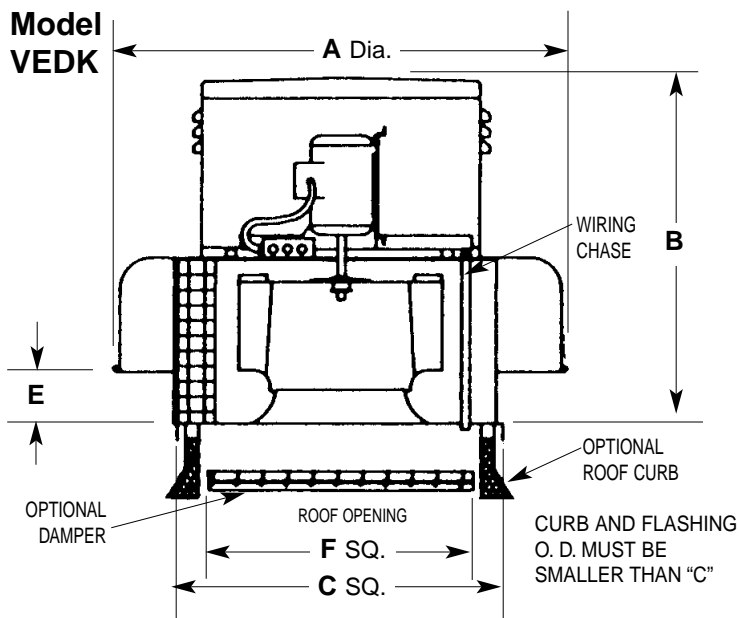

STANDARD FEATURES

- Spun and shaped aluminum housing, mill finish standard.
- Integral motor overload protection on all standard single phase motors.
- Disconnect switch on all motors except explosion proof.
- Ventilated motor compartment with motor out of airstream.
- Non-overloading, backwardly inclined wheel.
- Isolated, suspended motor wheel-drive assembly.
- Heavy gauge welded galvanized 1/2" x 1/2" birdscreen.
- Spark resistant construction.
- 2-speed motors include 2 separate disconnect switches.

DIMENSIONS [Listed In Inches]

Unit Size	Unit Diameter A	Unit Height B		Inside Curb Cap C	E	Roof Opening Square F	Curb O. D. Square	Damper Size Square	Approx. Wt. Less Motor [Lbs.]
		Standard Height	Extended Height						
06	25-3/4	13-3/8	21-7/8	15-1/2	2-7/8	11	14	10	30
08	25-3/4	14-3/4	23-1/4	15-1/2	4-1/4	11	14	10	30
10	27-3/4	20-3/8	23-7/8	17-5/8	3-1/2	13	16	12	35
12	27-3/4	22	25-1/2	17-5/8	5-1/8	13	16	12	35
15	32-3/4	28-1/2	33-1/4	20-1/2	6-1/2	16	19	15	50
18	37-3/4	29-5/8	34-3/8	25	7-3/4	20-1/2	23-1/2	19	65

MATERIAL AND THICKNESS [Listed In Inches]

Unit Size	Motor Cover				Curb Cap [Alum.]	Standard Wheel	Diffuser [Alum.]
	One Piece [Alum.]	Lid [Alum.]	Tube [Alum.]	Fan Shroud [Alum.]			
06	.051	.063	.040	.063	.050	Aluminum	.032
08	.051	.063	.040	.063	.050	Aluminum	.032
10	.063	.063	.040	.063	.063	Aluminum	.050
12	.063	.063	.040	.063	.063	Aluminum	.050
15	—	.063	.040	.063	.063	Aluminum	.063
18	—	.063	.040	.063	.063	Aluminum	.080

Metric (SI) Dimensions
Imperial [IP] on Reverse Side

CARNES COMPANY, Verona, WI. Phone: 608-845-6411 Fax: 608-845-6470 carnes@carnes.com www.carnes.com

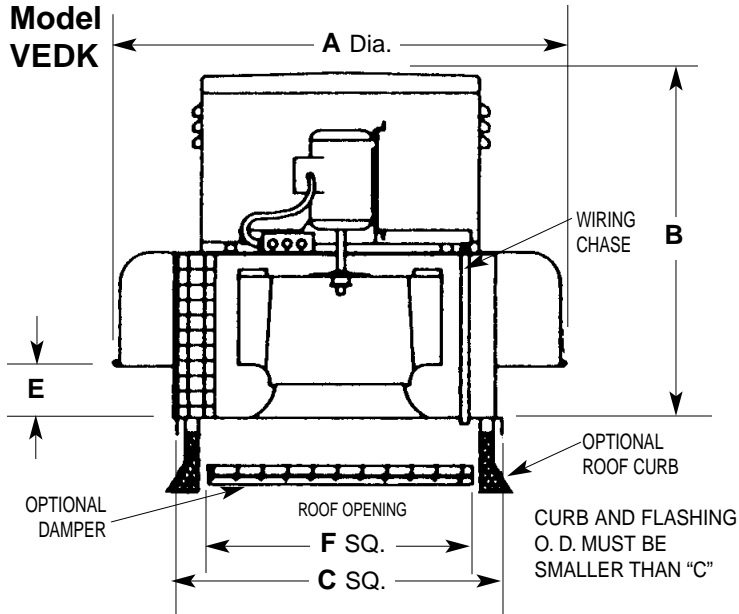

STANDARD FEATURES

- Spun and shaped aluminum housing, mill finish standard.
- Integral motor overload protection on all standard single phase motors.
- Disconnect switch on all motors except explosion proof.
- Ventilated motor compartment with motor out of airstream.
- Non-overloading, backwardly inclined wheel.
- Isolated, suspended motor wheel-drive assembly.
- Heavy gauge welded galvanized 12mm x 12mm birdscreen.
- Spark resistant construction.
- 2-speed motors include 2 separate disconnect switches.

DIMENSIONS (Listed In Millimeters)

Unit Size	Unit Diameter A	Unit Height B		Inside Curb Cap C	E	Roof Opening Square F	Curb O. D. Square	Damper Size Square	Approx. Wt. Less Motor (Kg)
		Standard Height	Extended Height						
06	654	340	556	394	73	279	356	254	14
08	654	375	591	394	108	279	356	254	14
10	705	518	606	448	89	330	406	305	16
12	705	559	648	448	130	330	406	305	16
15	832	724	845	521	165	406	483	381	23
18	959	752	873	635	197	521	597	483	30

MATERIAL AND THICKNESS (Listed In Millimeters)

Unit Size	Motor Cover				Curb Cap [Alum.]	Standard Wheel	Diffuser [Alum.]
	One Piece [Alum.]	Lid [Alum.]	Tube [Alum.]	Fan Shroud [Alum.]			
06	1.3	1.6	1.0	1.6	1.3	Aluminum	0.8
08	1.3	1.6	1.0	1.6	1.3	Aluminum	0.8
10	1.6	1.6	1.0	1.6	1.6	Aluminum	1.3
12	1.6	1.6	1.0	1.6	1.6	Aluminum	1.3
15	—	1.6	1.0	1.6	1.6	Aluminum	1.6
18	—	1.6	1.0	1.6	1.6	Aluminum	2.0