

Imperial [IP] Dimensions
Metric (SI) in Parentheses

CARNES COMPANY 448 S. Main St., P. O. Box 930040, Verona, WI 53593-0040 Phone: (608)845-6411 Fax: (608)845-6470 www.carnes.com

FRAME — 20 GA. CRS SIZES 6" (152) — 10" (254)
18 GA. CRS SIZES 12 (305) — 16" (406)

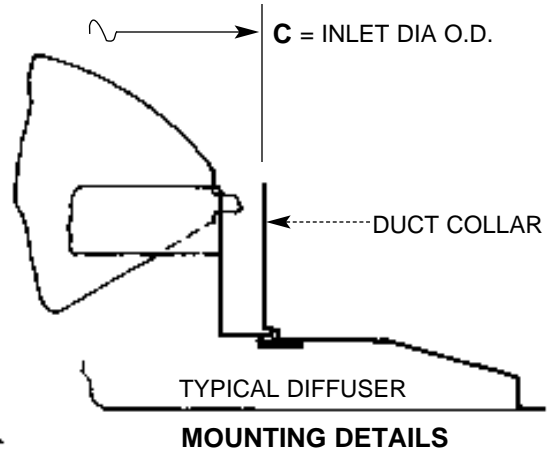
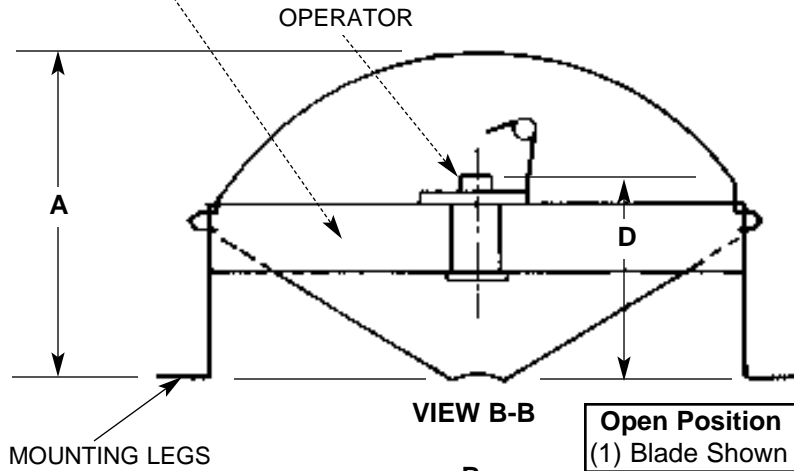

NOTE: Standard Finish #04 Gray
Electrocoat Enamel

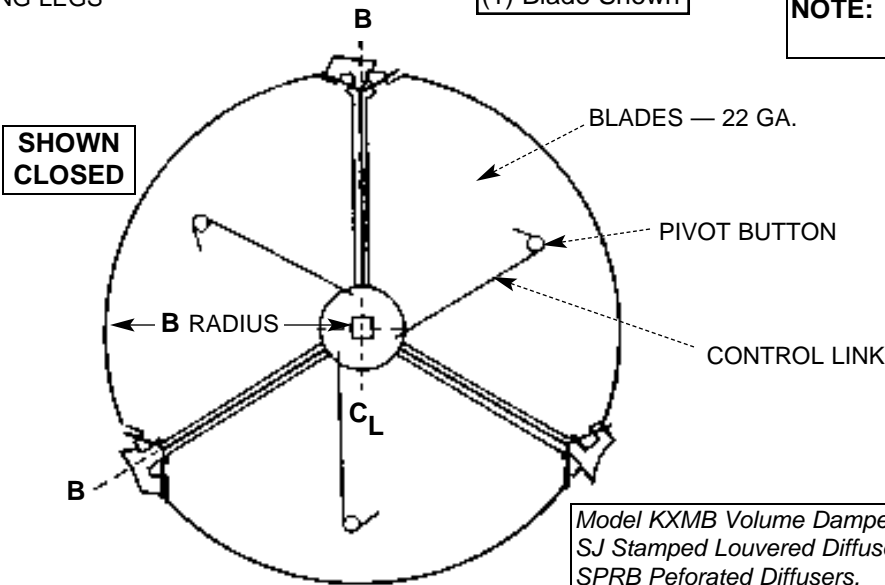

Model KXMB Volume Damper for use with Models SF and SJ Stamped Louvered Diffusers and Models SPAB and SPRB Peforated Diffusers.

DIMENSIONS LISTED IN INCHES (In Millimeters)

Model - Size	A	B	C	D
KXMB-06 (152)	2-7/16 (62)	2-3/4 (70)	5-7/8 (152)	2-1/8 (54)
KXMB-07 (178)	2-15/16 (75)	3-1/4 (83)	6-7/8 (178)	1-7/8 (48)
KXMB-08 (203)	3-7/16 (87)	3-3/4 (95)	7-7/8 (203)	2-1/8 (54)
KXMB-10 (254)	4-7/16 (113)	4-3/4 (121)	9-7/8 (254)	2-3/4 (70)
KXMB-12 (305)	5-5/16 (135)	5-3/4 (146)	11-7/8 (305)	3-3/4 (89)
KXMB-14 (356)	6-5/16 (160)	6-3/4 (172)	13-7/8 (356)	3-3/4 (89)
KXMB-16 (406)	7-5/16 (186)	7-3/4 (197)	15-7/8 (406)	4-1/4 (102)