

D U C T M A T E

Clutcher[®]

U.S. Patent No. 7,222,824



Mechanical System Hanger

Seismic Tested & Conforms to ICC Code Guidelines EG284

- May be used on a variety of mechanical systems
- Steel Cable & Clutcher mechanism sold separately
- Eliminates the need to stock pre-cut cable
- Tapered bore design for fast and easy installation
- Easily adjust hanging height by hand
- Extremely strong patented design
- Offers a 5 to 1 safety factor
- Available in a variety of sizes for different load weights
- Items can be hung at angles up to 60° from vertical
- Lightweight design reduces the risk of on-site accidents
- Aesthetically pleasing



DUCTMATE[®]

Industries, Inc.

DESCRIPTION

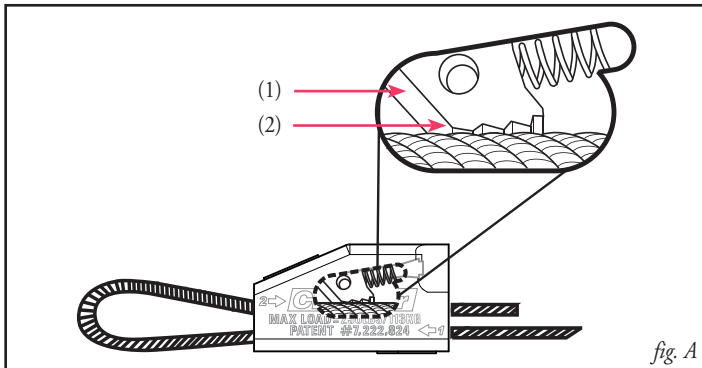

The Ductmate Clutcher System is a complete Steel Cable hanging system for HVAC and other mechanical applications.

The Ductmate Clutcher Steel Cable Hanging System consists of Ductmate Steel Cable and the Ductmate Clutcher mechanism. For the system to work properly, both components must be used. Ductmate Steel Cable is the only cable tested and approved for use with the Ductmate Clutcher system. Use of any other cable is not recommended, and will void the Ductmate warranty.

The Clutcher mechanism uses a serrated steel wedge to grip the Steel Cable (fig. A-1). The housing of the mechanism is cast out of metal. The shape and orientation of the wedge allows Steel Cable to pass through in one direction. When a load is applied to the Steel Cable in the opposite direction, the wedge grips the Steel Cable and presses it against the Clutcher mechanism housing, preventing it from moving (fig. A-2).

The Clutcher mechanism has two bores or passages. The first contains the wedge mechanism described above. The other bore allows the Steel Cable to pass freely through the housing.

BASIC USE

Labor-saving, versatile means for the suspension of static load HVAC and other mechanical applications indoors.

SPECIAL CHARACTERISTICS

- May be used on a variety of mechanical systems
- Cable and Clutcher mechanism sold separately
- Eliminates the need to stock pre-cut Cable
- Tapered bore design for fast and easy installation
- Easily adjust hanging height by hand
- Extremely strong patented design
- Offers a 5 to 1 safety factor
- Available in a variety of sizes for different weights
- Items can be hung at angles up to 60° from vertical
- Lightweight design reduces the risk of on-site accidents
- Aesthetically pleasing

TECHNICAL INFORMATION

Clutcher Mechanism

HOUSING: Zinc Cast
SPRING: Steel

WEDGE: Hardened Steel
END CAP: Metallic

Steel Cable

This system requires that Ductmate Steel Cable be used to meet testing and product specifications.

VERTICAL LOAD LIMITS

Clutcher System	Maximum Load	Compatible Steel Cable
CL10	125 lbs.	WR10
CL20	250 lbs.	WR20
CL30	650 lbs.	WR30
CL40	1250 lbs.	WR40

SAFETY

The Clutcher system has been engineered and tested with a 5:1 safety factor. The vertical load limit of the system is the maximum amount that can be supported. When designing a system, do not exceed the load limit of the Clutcher system.

PACKAGING INFORMATION

Size	Box Quantity	Bag Quantity	Bag/Boxes
CL10	500	10	50
CL20	400	10	40
CL30	50	5	10
CL40	25	5	5

CAUTION

- Never exceed the working load limit. In calculating working load, the full weight of the pipe with contents should be considered.
- Loads should be carried evenly across all hanging points.
- Always check that the locking mechanism is fully engaged.
- Do not use the Clutcher hanging system for lifting.
- Do not apply paint, lubricants or other coatings to the Clutcher system.
- Advise owner and other contractors and post other notices as necessary to insure that paint, lubricants or other coatings are not applied in the future.
- Do not use in corrosive or extremely humid conditions. Such conditions, over time, can cause metal components to corrode and fail.
- Use only with static loads. Not intended for use with oscillating loads.
- Prior to use, store product in a clean, dry and safe condition.
- Care should be taken that sharp edges or thin wall duct do not come in contact with the system and abrad or damage the Steel Cable.
- When adjusting or disconnecting Clutcher system, always make sure that load is fully supported by other means.
- Be sure building structure is capable of supporting the weight of the load.
- Use appropriate hanging method to prevent lateral movement in suspended duct.

ASSEMBLY METHODS

ROUND DUCT

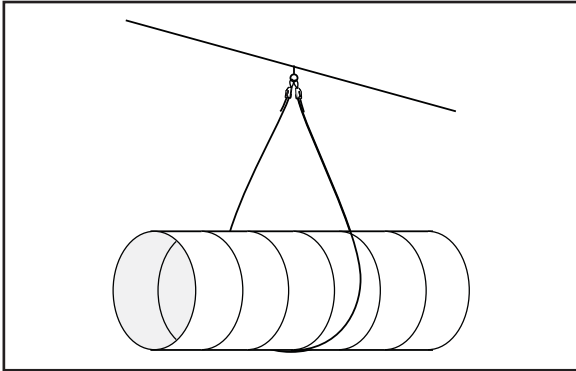

RECTANGULAR DUCT

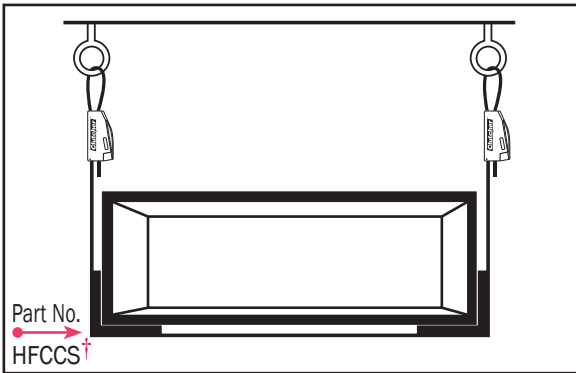

CABLE TRAYS

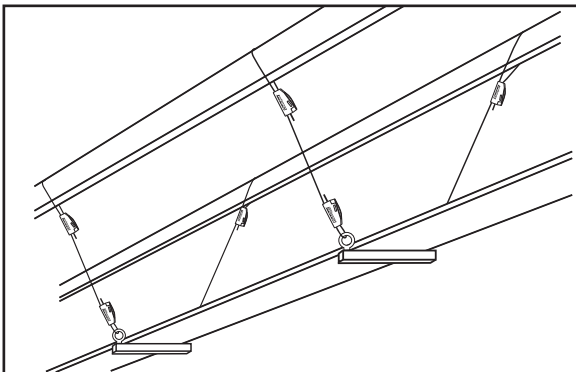

SIDE LOADINGS

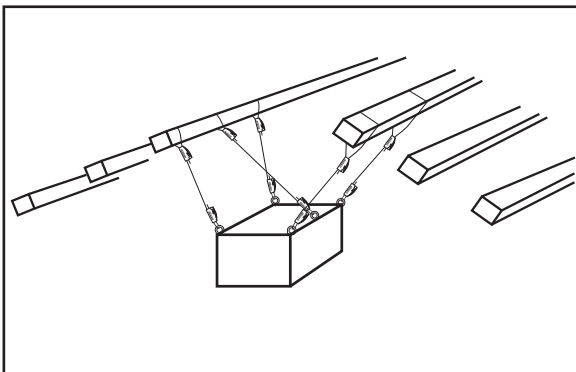

CLUTCHER MECHANISM DIRECTIONS

Attaching the Clutcher mechanism to the Steel Cable is quick and easy. Insert the Steel Cable through the free bore side, starting on the wider end of the Clutcher mechanism. Loop the Steel Cable around the upper attachment point, and into the wedge side of the Clutcher mechanism on the narrower end. There are arrows cast into the Clutcher mechanism body that indicate which way to insert the Steel Cable. At least 3 inches of Steel Cable should be extending out of the Clutcher mechanism housing. Repeat the process with a second Clutcher unit to cradle the load.

* Tip: When cutting Steel Cable, use a quality cutter designed for Steel Cable. Tin snips, diagonal cutters, and electrical cable cutters will not work; they will fray the ends of the Steel Cable and prevent it from sliding into the Clutcher mechanism correctly.

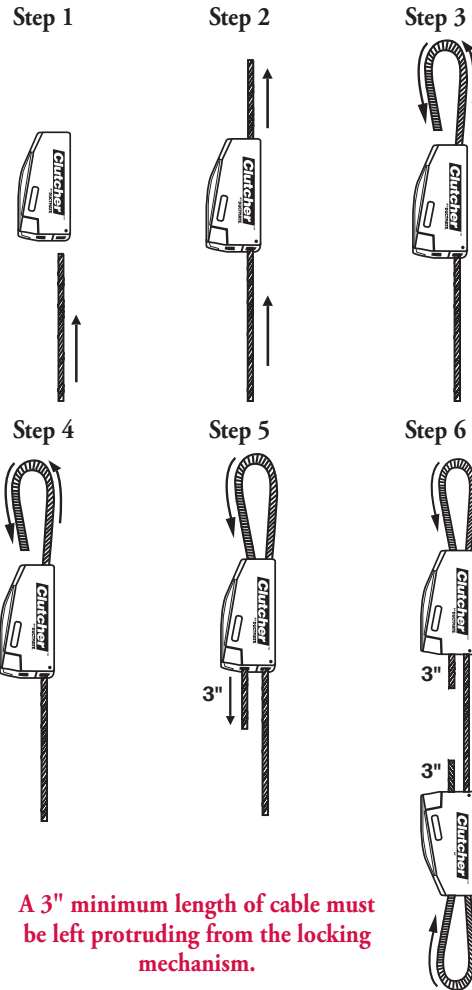

A 3" minimum length of cable must be left protruding from the locking mechanism.

WARNING

DO NOT attempt to use the Clutcher mechanism to splice two cables together, or attempt to secure the Steel Cable via only one bore in the Clutcher mechanism. The same Steel Cable must pass through both bores in the Clutcher mechanism.

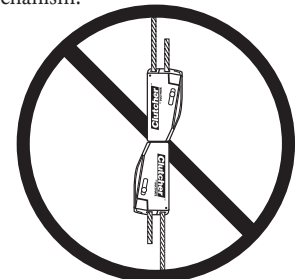
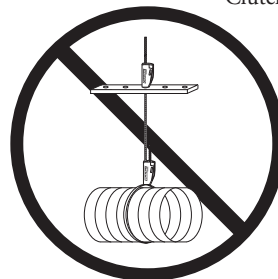

INSTALLATION INSTRUCTIONS

After the ductwork is leveled and the connection at the upper attachment secured with the Ductmate Steel Cable, then proceed with attaching the Clutcher mechanism to the object being suspended.



1. Insert Steel Cable through free flowing side of Clutcher mechanism.

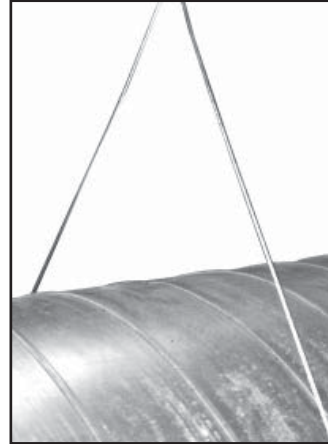

3. Wrap Cable around object being suspended (round duct in this case).

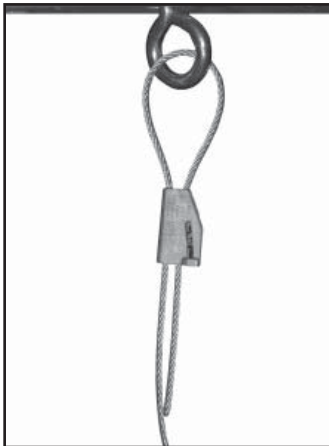

2. Loop Cable through eye bolt and into locking mechanism of clutcher.

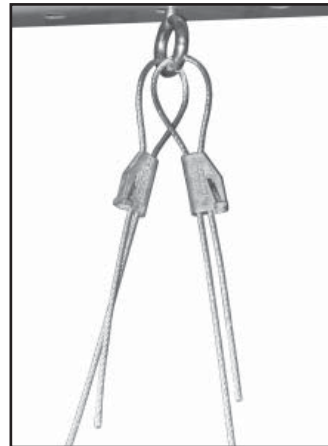

4. Loop Cable through the same eye bolt as in step 2 and secure with a second Clutcher using same method as steps 1 and 2.

NOTE

Make sure the load is evenly distributed over both Clutcher mechanisms.

LIMITED WARRANTY

Ductmate warrants that the Clutcher® Steel Cable hanging system, when used with Ductmate Steel Cable, and properly installed and maintained, will be free from defects in material and workmanship, and will comply with all written specifications made by Ductmate at the time of sale. Ductmate's warranty shall run for a period of one year from the date of manufacture.

Warranty Limitation

The warranty stated above is in lieu of all other warranties, express or implied, including but not limited to the implied warranties of MERCHANTABILITY AND FITNESS FOR A PARTICULAR PURPOSE. Although Ductmate may have suggested the product, or provided written or oral advice to the Purchaser, it is the Purchaser's responsibility to test and determine the suitability of the Clutcher® Steel Cable hanging system for the intended use and purpose, and Purchaser and/or its customer assumes all risk and liability whatsoever regarding such suitability.

Limitation of Liability

In the event of a breach of the above warranty, Ductmate's sole obligation, and Purchaser's sole and exclusive remedy, shall be, at Ductmate's option, repair or replacement of any defective products, or refund of an applicable portion of the purchase price. Ductmate shall have no liability for costs of removal or reinstallation of the product. The Purchaser agrees that no other remedy, including but not limited to loss of profits, loss sales, injury to person or property, or any other special, incidental or consequential damages, shall be available to the Purchaser for any claim arising out of this Agreement, regardless of whether such claim is made in contract or in tort, including strict liability in tort. In no event will Ductmate be obligated to pay damages to the Purchaser in any amount exceeding the purchase price that the Purchaser paid to Ductmate for the allegedly defective product.

HANGING CONFIGURATIONS

The type of hanging configuration used depends on the application. It is up to the end user to determine the best configuration for their particular installation.

The first method is called the single point saddle method (fig. 1). This method is to be the primary hanging method when using the Clutcher mechanism. The steel cable is looped through an eye bolt that is attached to the top support and then secured with a Clutcher. The same cable is then looped around the duct and back through the same eye bolt, then secured with a second Clutcher. This method ensures that the working load limit of the Clutcher is not adversely affected when larger duct is used.

The second method is the standard horseshoe (fig. 2). In this method, the Steel Cable is looped around the upper support and secured with a Clutcher mechanism, then routed under the ductwork and back up to the upper support to be secured with another Clutcher mechanism. This method helps to eliminate some swinging in the ductwork. It also doubles the safety factor of the Clutcher mechanism. When supported in this fashion, the tension in the Steel Cable is reduced by half. This mechanical advantage is the same concept that makes a block and tackle work. This configuration can be used for general purpose hanging when an increased factor of safety is desired.

Next is the spread horseshoe method (fig. 3). This is the same layout as above, but the Steel Cables are spread to the side, creating a measure of cross bracing. Since the Steel Cables are on an angle in this method, there is a reduction in their working load limit. However, since there are two Steel Cables, the total working load limit of this configuration is no less than the load limit of a single Steel Cable as with a standard loop configuration. This configuration can be used when additional stability is desired.

We'll call the last method the standard loop (fig. 4). The Steel Cable is looped around the upper support and secured with a Clutcher mechanism, then looped around the duct and secured with another Clutcher mechanism. The advantage of this method is its simplicity. It is suitable for applications where the duct will not experience lateral forces or be prone to swinging. An example of this would be a duct that is attached to a wall or other fixed element on each end. This configuration can be used for general purpose hanging.

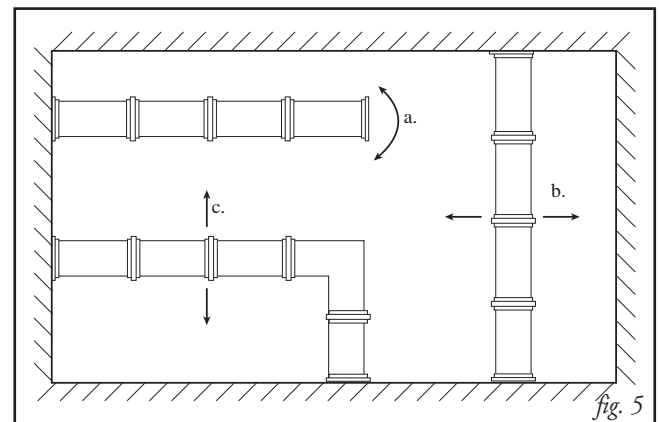
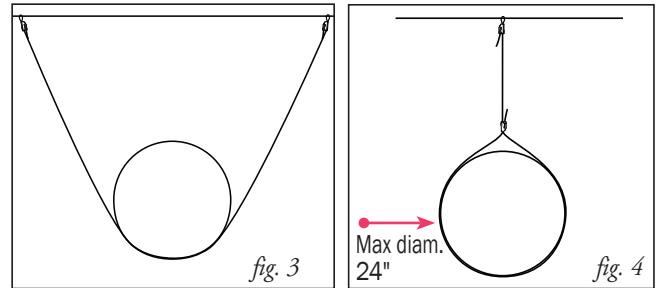
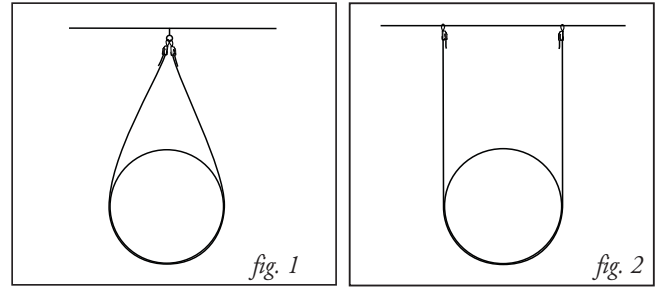

STABILITY IN THE DUCT SYSTEM

When installed, the duct system should be stable enough that it doesn't swing or move when in use. Excessive movement can lead to fatigue failures in the joints or connections.

Typically, a duct run will be attached to some rigid object, such as a wall or equipment at one or both ends of the run.

When a run of duct is anchored only at one end, and cantilevered outward, the free end of the run can be expected to swing laterally (fig. 5a). When a long run of duct is anchored at both ends, the free center of the duct run may swing laterally (fig. 5b). If two sections of duct anchored at one end converge at a 90° angle (fig. 5c), free sections of duct may swing laterally.

In an application where movement is not expected, the single point saddle method (fig. 1), the standard horseshoe method (fig. 2), and the standard loop (fig. 4) can be used. When lateral movement needs to be minimized, the spread horseshoe (fig. 3) should be used.

HANGING ON AN ANGLE

When using the spread horseshoe method, the tension in the Steel Cable increases. Table 1 shows the reduced working load limits for each size of Clutcher mechanism, determined by the angle in the steel cable.

MAXIMUM LOADS FOR NON-VERTICAL SUPPORT

(Table 1: Load Limits)

Angle from Vertical (in degrees)	Maximum Load for Clutcher Mechanism (in lbs.)			
	CL10	CL20	CL30	CL40
0	125	250	650	1250
5	124.5	249.0	647.5	1245.2
10	123.1	246.2	640.1	1231.0
15	120.7	241.5	627.9	1207.4
20	117.5	234.9	610.8	1174.6
25	113.3	226.6	589.1	1132.9
30	108.3	216.5	562.9	1082.5
35	102.4	204.8	532.4	1023.9
40	95.8	191.5	497.9	957.6
45	88.4	176.8	459.6	883.9
50	80.3	160.7	417.8	803.5
55	71.7	143.4	372.8	717.0
60	62.5	125.0	325.0	625.0

ACCESSORIES

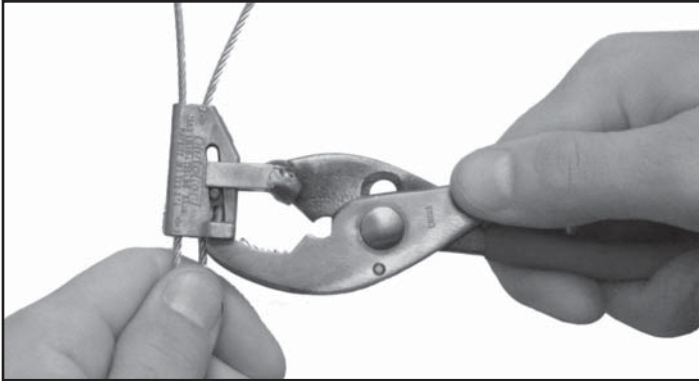

Ductmate DeClutcher

A custom hand tool designed to quickly and easily release the wedge on the Clutcher mechanism (CL10 and CL20 only), in order to release the Steel Cable from the Clutcher mechanism. (Part Number: CLTOOL1020).

WARNING: When adjusting a Clutcher mechanism, be sure that the load is supported by alternate means before pulling back on the wedge and releasing the Steel Cable.



Ductmate Light Duty Steel Cable Cutter

A small, high-quality cutter designed for Steel Cable. Tin snips, diagonal cutters, and electrical Cable cutters fray the ends of the Steel Cable and prevent it from sliding into the Clutcher mechanism correctly. The Ductmate Steel Cable Cutter provides a clean cut with less effort. (Part Number: HFWRC model shown works with Ductmate Steel Cable part numbers WR10 & WR20.)

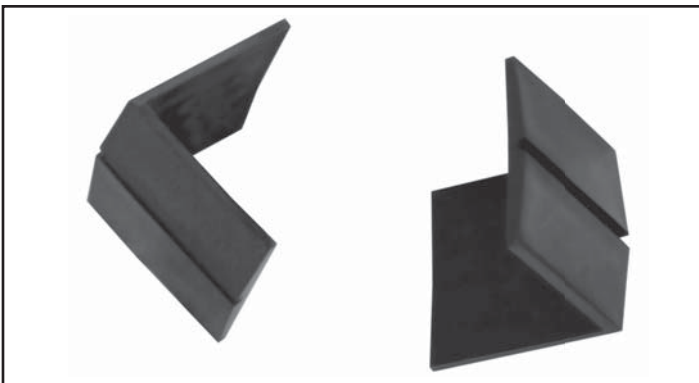

Rectangular Duct Corner Saddles

This optional accessory item is designed to eliminate abrasion of rectangular ductwork with the use of a Steel Cable hanging system. †(Part Number: HFCCS)



Ductmate Heavy Duty Steel Cable Cutter

A quality cutter designed for heavy Steel Cable, available through Grainger®. Inferior cutters fray the Steel Cable and prevent it from sliding into the Clutcher mechanism correctly. The right steel cable cutter provides a clean cut with less effort. (Grainger Part Number: 2G996 model shown works with Ductmate Steel Cable WR30 & WR40.)



Charleroi, PA
210 Fifth Street
Charleroi, PA 15022
800-245-3188
724-258-0500
FAX: 724-258-5494

www.ductmate.com

Lodi, CA
810 S. Cluff Avenue
Lodi, CA 95240-9141
800-344-3270
209-333-4680
FAX: 209-333-4678



This spec data is printed on paper that meets the Certified Fiber Sourcing requirements of the SFI program and contains 10% recycled content

Distributed By:



Ductmate is a proud member of the following organizations: